

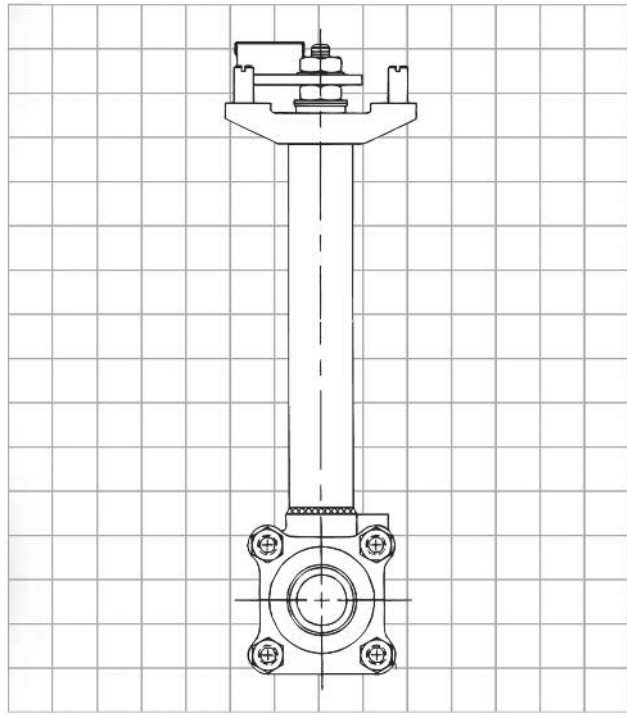

AN ISO 9001 REGISTERED COMPANY



C4, C44, and C51 Ball Valves for Cryogenic Service

**High-performance, shutoff
valves for intermittent and
continuous flow applications
with temperatures to -425°F**

Flow Control

Flowserve Worcester Controls presents the quality solution to problems of manual and automatic control of cryogenics.

Flowserve Worcester Controls has the quality solution for tough applications involving all types of cryogenics; oxygen, hydrogen, methane, ammonia, nitrogen, fluorine, LNG and deuterium.

Our complete line of cryogenic valves, backed by years of successful field experience, incorporates superior technology and design. This means automatic or manual control of cryogenic fluids with no contamination, no fluid degradation and no waste while assuring safety for workers, property and the environment. The wrong specifications here can turn an inferior valve into a time bomb. Tough applications demand Worcester Controls' special service cryogenic valves.

Here's Why:

Positive Ball Cavity Relief – An upstream relief hole in the ball prevents dangerous overpressure due to thermal expansion. On extended stem valves through 2", a one-piece stem with alignment pin assures proper orientation of the ball.

Pressure Safe Stem – Both one-piece and two-piece, assembled-inside-the-body stems are safe from blowout and are supported with Polyfill® thrustwashers.

Zero Leak Packing – Belleville live-loaded TFE packing rings and stem centering followers assure zero leakage through the toughest, high-cycle applications.

Effective Bonnet Extensions – The stem extensions of Worcester Controls' cryogenic valves conform to standard industrial practices. That means wall thickness and lengths that keep heat transfer down, the packing frost-free, operational torques low, and actuators solidly supported.

High-Performance/Low-Thermal Stress – The special "part compatibility" design of valve parts, Polyfill seats and body seals assure tight shutoff, zero body leakage and low torque through large thermal excursions from ambient to -425°F.

Valves Designed for Automation – Approximately 40% of cryogenic installations require fail-safe operation or automatic on/off control. Worcester Controls has the pneumatic and electronic, computer-compatible controls for your installation.

Valves Designed for Fire Safety – A Series 94 double-graphite, stem-sealed fire-tight version of our cryogenic valve is available through the Custom Products Department. These valves are especially effective in hydrogen and liquefied natural gas systems.

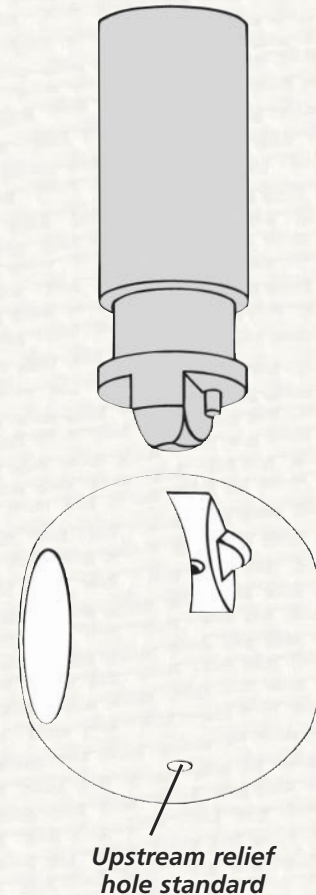

Flow Control

No Leak Seats and Seals

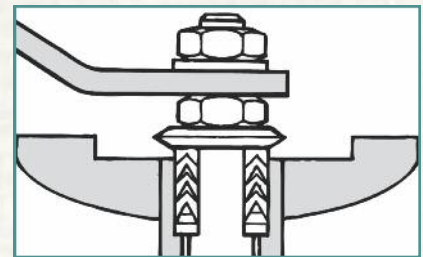
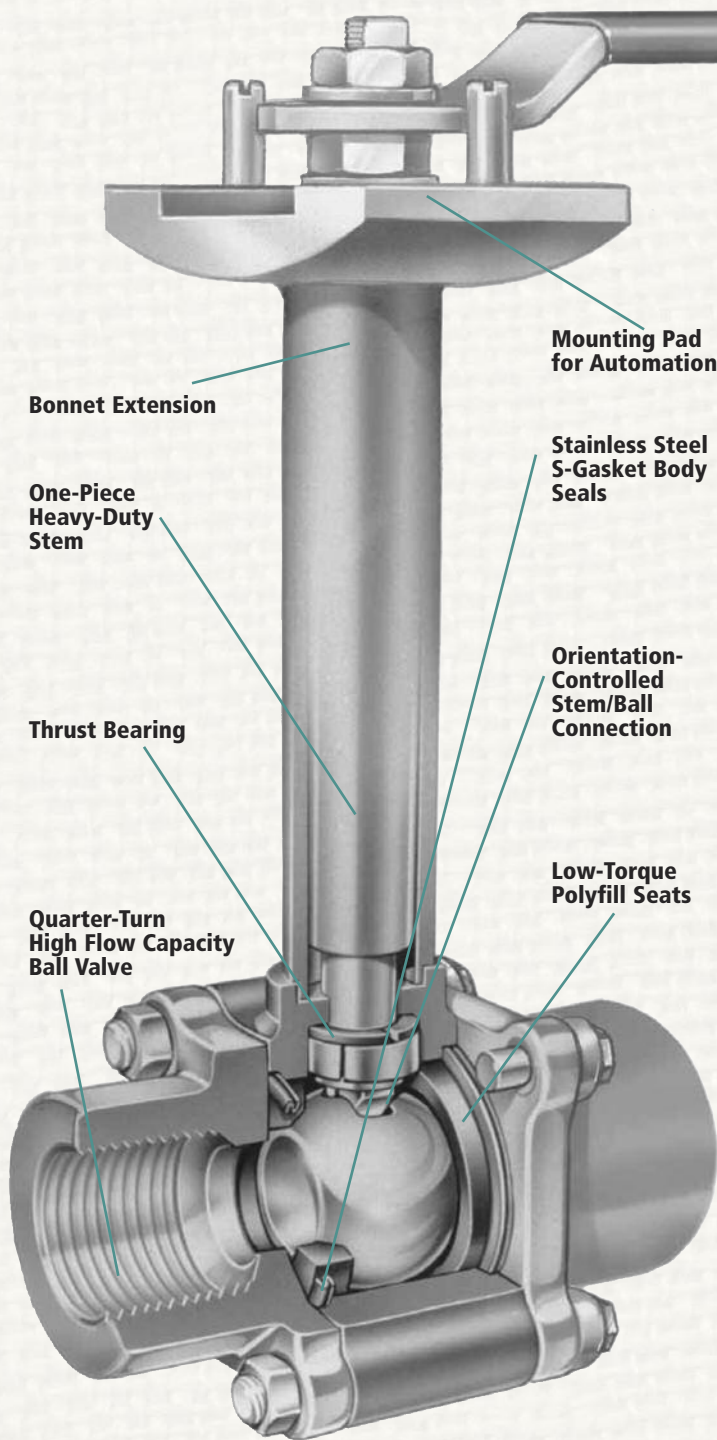

Central to the Worcester cryogenic design is a rugged, one-piece, pressure safe stem with a Polyfill thrust bearing and stainless steel split ring. You get design safety and low operational torque. Polyfill seats give you tight shutoff throughout the temperature range. With an orientation-controlled stem/ball connection and an upstream hole in the ball, you get positive overpressure protection.

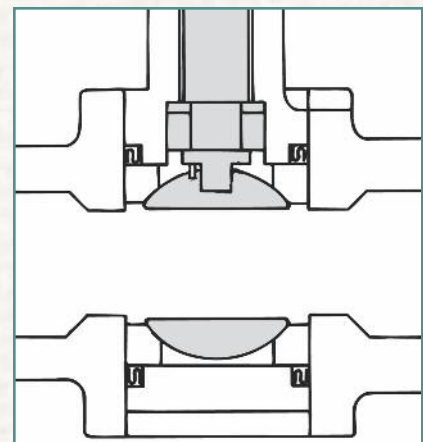

Flow Control

Cryogenic Valve Configurations

Flowserve Worcester Controls cryogenic valves are available in four basic body configurations; C44 (1/4"-2"), C44 Diverter (1/2"-2"), C4 Wafer (3"-6"), and C51 Flanged (3"-6"). All four valve styles offer the same features: exclusive Polyfill seats, all stainless steel construction, pressure-safe stem, extension bonnet lengths, positive ball cavity relief and low operational torques.

C44 – The Worcester cryogenic valve incorporates many of the features of the Series 44 line of valves. Three-piece construction makes it easy to install, versatile in application and simple to maintain. By removing three of the body bolts and loosening the fourth, the valve may be swung out of line. In welded or soldered piping systems, all four body bolts may be removed and the center section lifted out for maintenance or replacement. A variety of connections are available; screwed end, socket weld, butt weld and solder/sweat ends.

C44 Diverter – The cryogenic diverter valve accepts media through the bottom inlet port and directs it to one of two side ports. There are two ball porting configurations; Porting No. 1 directs flow from one outlet port to the other through a 90° rotation. Porting No. 2 diverts media from one outlet port to the other through a 180° rotation. With Porting No. 2, the flow can be turned off by positioning the valve at 90° rotation. A Porting No.1 diverter valve can be automated pneumatically or electrically. A Porting No. 2 valve may be operated by a Series 75 electric actuator. Bottom connection options are the same as standard valve (except butt weld).

C4 Wafer – The Worcester wafer is a flangeless cryogenic valve that mounts between ANSI Class 150 or 300 flanges. The extension construction is slightly different than the smaller C4 valves and includes a two-piece pinned stem extension and solid ring 15% glass-filled TFE stem seals and a virgin TFE body seal.

C51 Flanged – The C51 is identical in internal construction to the wafer cryogenic valve. The body is cast with ANSI Class 150 flanges.

Valves Without Stem Extension – Valves in all four configurations are available without stem extensions for intermittent cryogenic service.

Codes and Standards: Praxair® Specification GS-38 and GS-40. Valves may comply with ANSI B16.34 if ordered with V58 suffix. Brass and wafer valve bodies are not covered by ANSI B16.34.



C44 Brass or Stainless Steel



C44 Diverter



C4 Wafer



C4 Flanged

Valves Without Stem Extensions

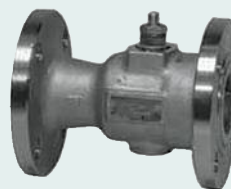

Flow Control

Applications

- Over-the-Road LNG-LPG Trailers
- Terminal Unloading Stations
- High-Purity Cryogenic/Gas Systems
- LNG Storage and Distribution
- CO2 and Nitrogen Injection for Enhanced Oil Recovery
- Over-the-Road CO2, LNG, Food Carriers
- Petroleum Refining Unleaded Gasoline (Gas Treatment Skids)
- Lyophilization Systems
- Air Separation Plants
- Liquid and Gaseous Oxygen for Steel Production*
- Inerting and Heat Treatment
- Liquid Ammonia Systems (consult factory)

* Consult factory prior to ordering

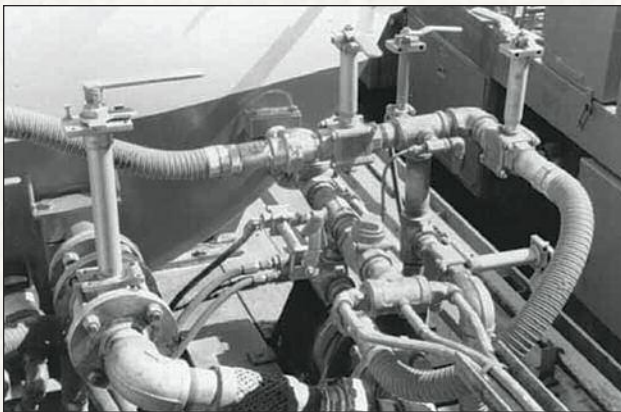

Clean Room Assembly

Environmental Control

Before final assembly, valve components are cleaned and degreased. Cleaning and tagging procedures for Flowserve Worcester cryogenic valves are based on Praxair Specification GS-38 and GS-40.

Assembly occurs in a Class 100 environment, per Federal Standard 209B for assembly and test.

The Stainless Steel Passivation – Worcester engineering specifications strictly define procedures for cleaning, descaling and passivating stainless steel parts. Inspection is performed with a copper sulfate test per ASTM A380.

Wipe Test – All wetted components are wipe tested using Whatman® #44 paper.

Helium Leak Test – Valves are dry tested, internally pressurized with 80 psi helium and checked with a helium leak detector (Helium Mass Spectrometer sensitive to 1×10^{-5} cc/sec.).

Vacuum Sealed – After all testing has been completed, cryogenic valves are capped with protective plastic end caps, stamped, tagged and heat sealed in 4 mil polyethylene bags. This ensures valve integrity up to the point of installation.

Custom Testing – On request, special material, valve integrity, tightness and operational testing can be performed with valves submerged in liquid nitrogen.

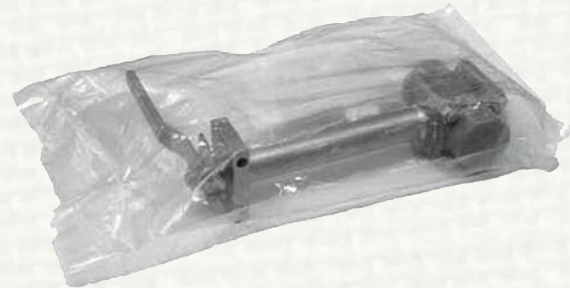

Flow Control

Throttling Control of Cryogenics

Worcester's characterized metal-seated control valves for modulating service offer many advantages over traditional globe valves for demanding cryogenic applications.



Rotary Concept

Eliminates expensive high-maintenance stuffing box design of rising stem globe valves.

Eliminates the unbalanced, heavy actuators of extended bonnet globe valves.

Reduces the size of the control valve package by one third.

Characterized Seats

- High accuracy
- High rangeability
- Class VI shutoff or better
- Modified characteristics for better control
- Smaller valve sizes than conventional globe valves

Lower Material Cost

For applications such as oxygen, the added cost is significantly lower than globe valves.

Choice of Pneumatic or Electric Actuation

Pneumatic Series 39 actuators available with Pulsair® loop-powered, intrinsically safe positioner or all-pneumatic positioners for precise throttling control.

Economical, Series 75 electric actuators with Series DFP17 DataFlo™ positioner or Series DFC17 DataFlo controller allow for dependable throttling control in colder environments where moisture in the airlines can freeze or in systems where compressed air is not available.

Easier direct electronic interface.

Characterized seat control valves for cryogenic service are available through Worcester's Custom Products Department.

Pneumatic and Electric Automation

Easy automation for on/off service is assured by our Series 39 pneumatic or Series 75 electric actuators. Both are backed by our exclusive two-year warranty. The Series 39 actuator is the toughest and most versatile rotary actuator available. Fail-safe capability, and mechanical and proximity limit switches provide system safety and valve position feedback.

Mount a Series 75 electric actuator and you have a high-performance control valve package specifically designed for computer or PLC control. A variety of options allow you to select the performance criteria and feedback information you desire. The Series 75 is available with TYPE 1, 4, 7 or 9 enclosures.



**Series 75
Electric Actuator**



**Series 39
Pneumatic Actuator**



**Series 39 Pneumatic Actuator
with Pulsair Positioner**

Flow Control

Specifications

C44 and C44 Diverter Valves Without Extensions

Valve Sizes:	1/4", 3/8", 1/2", 3/4", 1", 1 1/2" and 2" (diverter not available in 1/4" and 3/8").
Styles:	Unidirectional flow, three-piece design Bottom entry, one-piece, blowout-proof stem diverter-V1, V2 porting
Body:	ASTM A351 CF8M, 316 or CF3M, 316L stainless steel ASTM B283 C37700, brass
Pipe Ends:	ASTM A351 CF3M (316L) stainless steel ASTM A351 CF8M (316) stainless steel ASTM B283 C37700, brass
Ball:	ASTM A479 316 Condition A stainless steel or ASTM A351 CF8M stainless steel ASTM B16 HO2 Upstream relief hole (V3) in ball to relieve cavity pressure.
Stem:	ASTM A479 316 stainless steel, Condition A ASTM B16 HO2
Seats:	Polyfill
Body Seals:	TFE coated 316 stainless steel gaskets
Externals:	300 series stainless steel
End Connections:	SE – Screwed pipe ends (NPT) (dimensions to ANSI B1.20.1) SW – Socket weld ends (dimensions to ANSI B16.34) SW0 – Socket weld ends for O.D. tubing to ASTM A269 (stainless steel only) BW1 – Butt weld ends for schedule 10 pipe (dimensions to ANSI B16.25) (stainless steel only) TE – Tube ends (sweat ends for type K, L and M copper tubing to ASTM B88) (brass only)
Follower:	AISI 316L stainless steel
Packing:	Polyfill

C4 Wafer Valves and C51 Flanged Valves with and without Extensions

Valve Sizes:	3", 4" and 6"
Style:	Unidirectional flow, wafer/flangeless and flanged design Blowout-proof stem
Valve Ratings:	Wafer – fits between ANSI Class 150 and 300 flanges Flanged – ANSI Class 150
Body and End Plug:	ASTM A351 CF8M stainless steel ASTM B584 C83600 brass (wafer only)
Ball:	ASTM A351 CF8M ASTM B584 C83600 brass (wafer only)
Stem:	ASTM A479 316 stainless steel Condition A
Seats:	Polyfill
Body Seal:	TFE Virgin
Stem Seals:	TFE – 15% glass filled
Centering Washers:	AISI 316 stainless steel ASTM B121 C34200 brass (wafer only)
Thrust bearing:	TFE – 25% glass filled
Follower:	3", 4" ASTM A479 316 stainless steel 6" ASTM A269 300 stainless steel
Externals:	300 series stainless steel

C44 and C44 Diverter Valves With Stem Extensions

Valve Sizes:	1/4", 3/8", 1/2", 3/4", 1", 1 1/2" and 2" (diverter not available in 1/4" and 3/8")
Styles:	Unidirectional flow, three-piece design Extended, one-piece, blowout-proof stem diverter-V1, V2 porting
Body:	ASTM A351 CF3M, 316L stainless steel ASTM B283 C37700, Brass
Pipe Ends:	ASTM A351 CF3M (316L) stainless steel ASTM A351 CF8M (316) stainless steel ASTM B283 C37700, brass
Ball:	ASTM A479 316 Condition A stainless steel or ASTM A351 CF8M stainless steel ASTM B16 HO2
Stem:	ASTM A479 316L, 316L Condition A solution annealed. One-piece stem with alignment pin in bottom and arrow on top for proper orientation of ball in valve. Gives positive external indication of ball position.
Seats:	Polyfill
Body Seals:	TFE coated 316 stainless steel gaskets
Stem Packing:	V-ring packing (TFE style C-VH rings) Optional "G7" graphite chevron packing available for valve horizontal applications
Thrust bearing Upper:	(2) Polyfill
Followers:	ASTM A479 316L
Split Ring:	ASTM A479 316L
Split Thrust bearing Lower:	Polyfill (1"-2"), PBI (1/2", 3/4")
Externals:	300 series stainless steel
End Connections:	SE – Screwed pipe ends (NPT) (dimensions to ANSI B1.20.1) SW – Socket weld ends (dimensions to ANSI B16.34) SW0 – Socket weld ends for O.D. tubing to ASTM A269 (stainless steel only) BW1 – Butt weld ends for schedule 10 pipe (dimensions to ANSI B16.25) (stainless steel only) TE – Tube ends (sweat ends for type K, L and M copper tubing to ASTM B88) (brass only)

General Specifications

Worcester's stainless steel cryogenic valves are designed to meet B16.34 specifications. For compliance to the code, special hydro testing is required. Full CMTRs (Certified Material Tests Reports) on pressure vessels are available. Please order V-58 for complete B16.34 compliance and CMTRs.

Shutoff:	The valve exceeds the tightness requirements of recognized industry standards (.10 SCFH per inch of valve @ 100 psi helium and -320°F maximum leakage).
Packaging:	End connections are capped or plugged, and valves are placed in 4 mil thick (minimum) polyethylene bags and heat sealed.
Operation:	Lever handle, pneumatic or electric actuators. Valve must be installed with extension bonnet within 30° of true vertical.
Cleaning:	Cleaning for all valves is based on the oxygen cleaning procedures of Praxair (formally Linde Division) Spec. G538 and G540. Body, ball, stem and pipe ends degreased.
Lubrication:	Molykote® 321
Assembly:	Assembly and test in a Class 100 environment per Federal Standard 299B is available upon request.
Testing:	Valves are dry tested, internally pressurized with 80 psi helium, check with helium leak detector (Helium Mass Spectrometer) sensitive to 1 x 10 ⁻⁵ cc/sec. Upstream relief hole (V3) in ball to relieve cavity pressure. Slot in top of ball for insertion of stem alignment pin to ensure proper orientation in valve. Gives external positive indication of ball position (1/4" - 2" valves).
Temperature Range:	-425°F to +180°F

Flow Control

Specifications

Body Temperature vs Bonnet Temperature

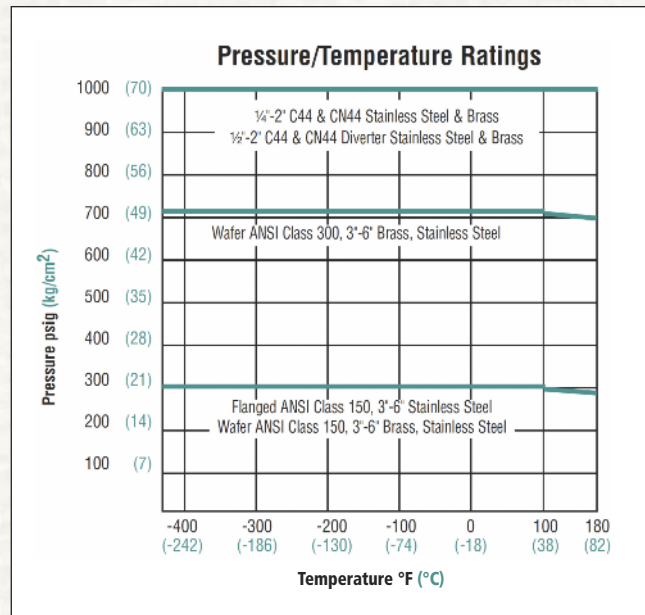
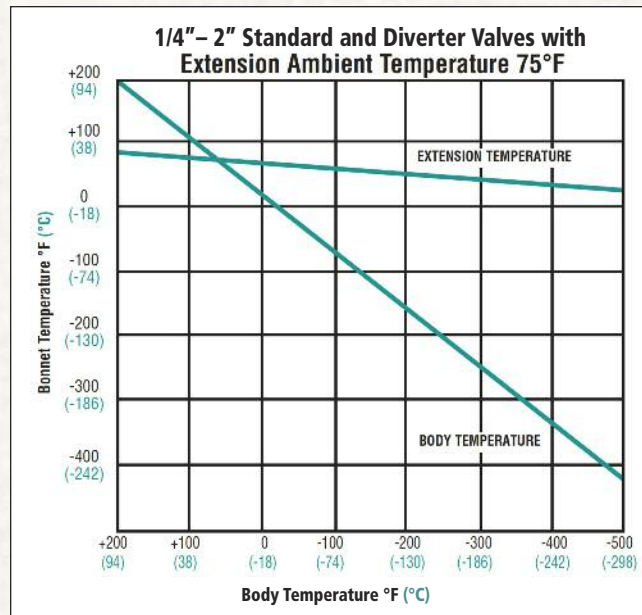

Flow Coefficient

Cv Values and Equivalent Lengths of Pipe

Valve Size	C _v				Equivalent Length of Schedule 40 Pipe (ft.)			
	C44	C44 Diverter	Wafer	Flanged	C44	C44 Diverter	Wafer	Flanged
1/4"-1/2"	8	3			3.1	19.6		
3/4"	12	5			6.3	30.4		
1"	32	10			3.1	27.8		
1 1/2"	82	24			4.3	43.5		
2"	120	36			7.5	22.7		
3"			350	350			7.1	7.1
4"			720	720			6.9	6.9
6"			1020	1020			20.4	20.4

Pressure and Torque for Automated Valves

Before the actuator can be sized for any given valve application, the amount of torque required by the valve must be determined. The operating torque of the ball valve is influenced by a number of factors. Some are design and materials related, others are application (service conditions) related. Design related factors include the type of materials of the valve seats while application factors include system pressure, media, and frequency of operation.

Flow Control

Parts Identification

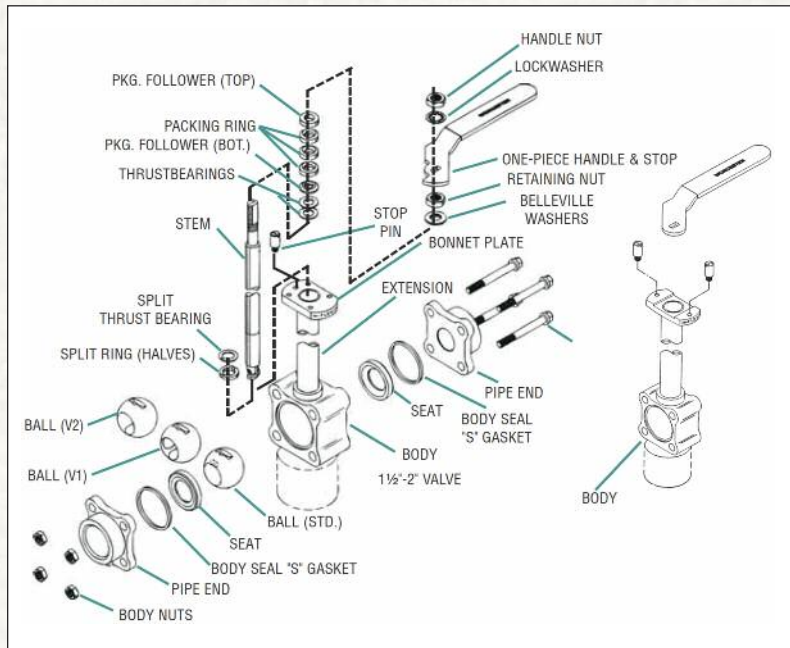

1/4" - 2" Cryogenic C44 and C44 Diverter Valves with Extension

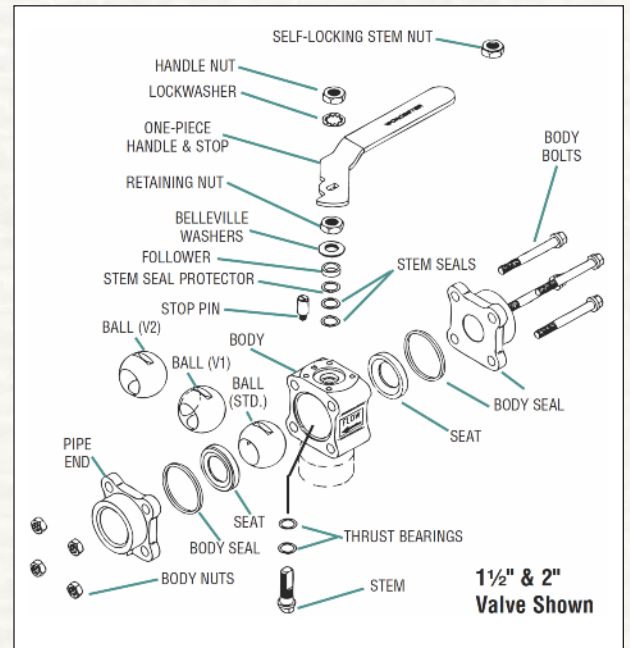

1/4" - 2" Cryogenic C44 and C44 Diverter Valves without Extension

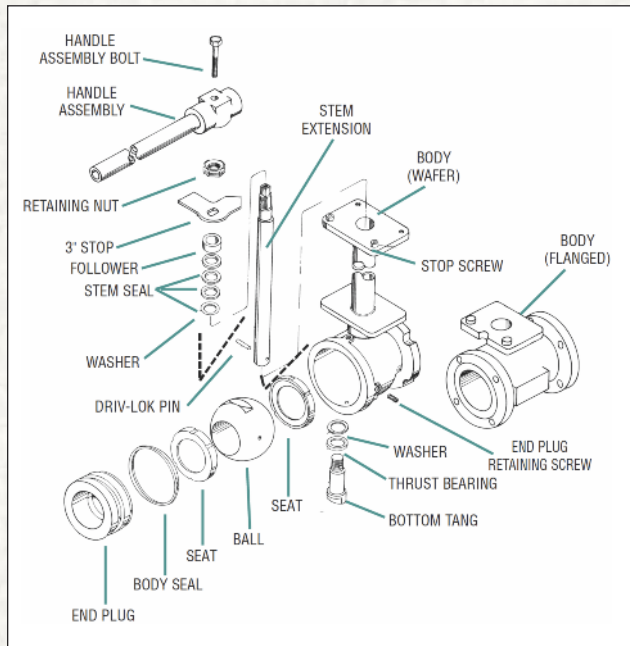

3" - 6" Cryogenic C4 and C51 Valves with Extension

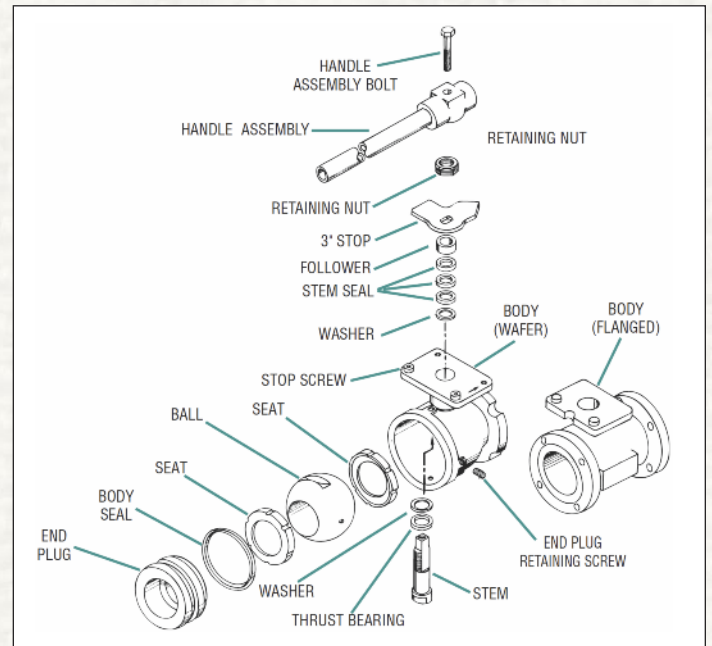

3" - 6" Cryogenic C4 and C51 Valves without Extension

Flow Control

Dimensions

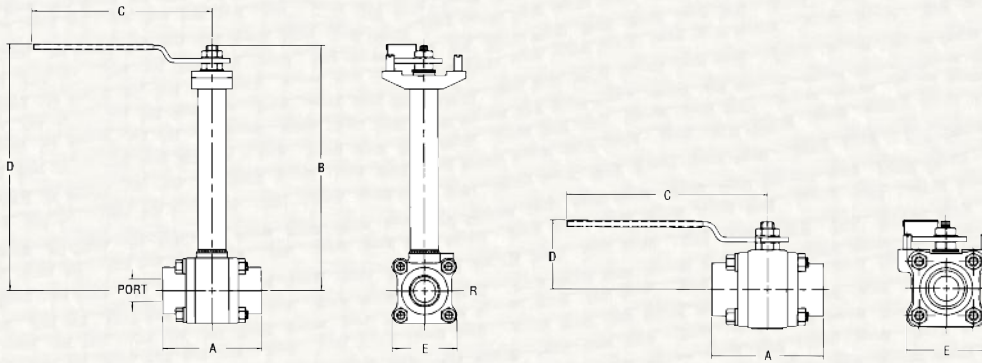

1/4" - 2" Cryogenic C44 Ball Valves Extended and Non-extended Bonnets

Valve Size	A	B	C		D		E	Port	Approx. Weight lbs. (kg.)	
			With Ext.	Without Ext.	With Ext.	Without Ext.			With Ext.	Without Ext.
1/4", 3/8", 1/2"	2.54 (64.52)	7.86 (199.6)	6.53 (166)	5.53 (140)	7.87 (200)	1.76 (44.7)	1.75 (44.4)	.44 (11.8)	3.0 (1.4)	1.1 (0.5)
3/4"	2.76 (70.10)	7.96 (202.2)	6.53 (166)	5.53 (140)	7.97 (202)	1.86 (47.2)	2.00 (50.8)	.56 (14.22)	3.5 (1.6)	1.8 (0.8)
1"	3.66 (92.96)	8.91 (226.3)	6.53 (166)	6.53 (166)	8.94 (227)	2.28 (57.8)	2.38 (60.4)	.81 (20.57)	5.0 (2.3)	3.1 (1.4)
1 1/2"	4.50 (114.30)	10.23 (259.8)	8.03 (204)	8.03 (204)	10.25 (260)	2.83 (71.9)	3.16 (80.3)	1.25 (31.75)	11.1 (5.0)	6.2 (2.8)
2"	4.94 (125.48)	10.41 (264.4)	8.03 (204)	8.03 (204)	10.44 (261)	3.02 (76.7)	3.56 (90.4)	1.50 (38.10)	14.4 (6.5)	9.5 (4.3)

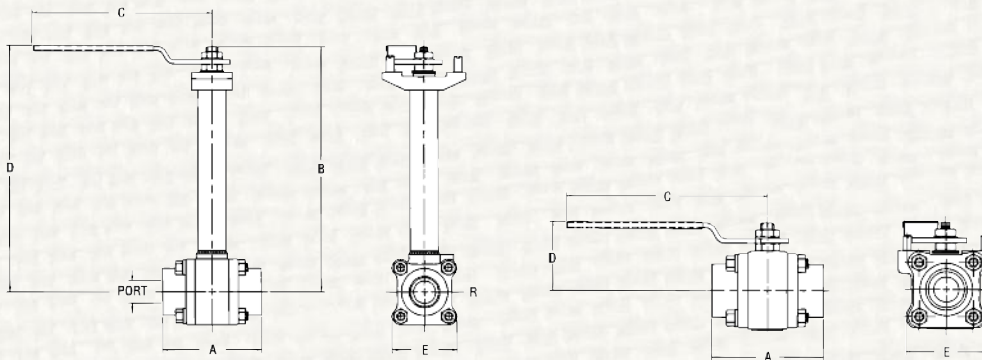

1/2" - 2" Cryogenic C44 Diverter Ball Valves Extended and Non-extended Bonnets

Valve Size	A	B	C		D		E	R	End Port Dia.	Bottom Port Dia.	Approx. Weight - lbs. (kg.)	
			With Ext.	Without Ext.	With Ext.	Without Ext.					With Ext.	Without Ext.
1/2"	2.54 (64.52)	7.86 (199.6)	6.53 (166)	5.53 (140)	7.87 (200)	1.76 (44.7)	1.75 (44.4)	2.25 (51.0)	.38 (9.70)	.34 (8.64)	3.2 (1.5)	1.6 (0.7)
3/4"	2.76 (70.10)	7.96 (202.2)	6.53 (166)	5.53 (140)	7.97 (202)	1.86 (47.2)	2.00 (50.8)	2.50 (63.5)	.52 (13.20)	.50 (12.70)	3.8 (1.7)	2.0 (0.9)
1"	3.66 (92.96)	8.91 (226.3)	6.53 (166)	6.53 (166)	8.94 (227)	2.28 (57.8)	2.38 (60.4)	3.06 (77.7)	.75 (19.10)	.72 (18.29)	5.3 (2.4)	3.6 (1.6)
1 1/2"	4.50 (114.30)	10.23 (259.8)	8.03 (204)	8.03 (204)	10.25 (260)	2.83 (71.9)	3.16 (80.3)	3.56 (90.4)	1.25 (31.75)	1.12 (28.45)	12.5 (5.7)	7.2 (3.3)
2"	4.94 (125.48)	10.41 (264.4)	8.03 (204)	8.03 (204)	10.44 (261)	3.02 (76.7)	3.56 (90.4)	3.94 (100.1)	1.50 (38.10)	1.38 (35.05)	14.7 (6.7)	9.6 (4.4)

Flow Control

Dimensions

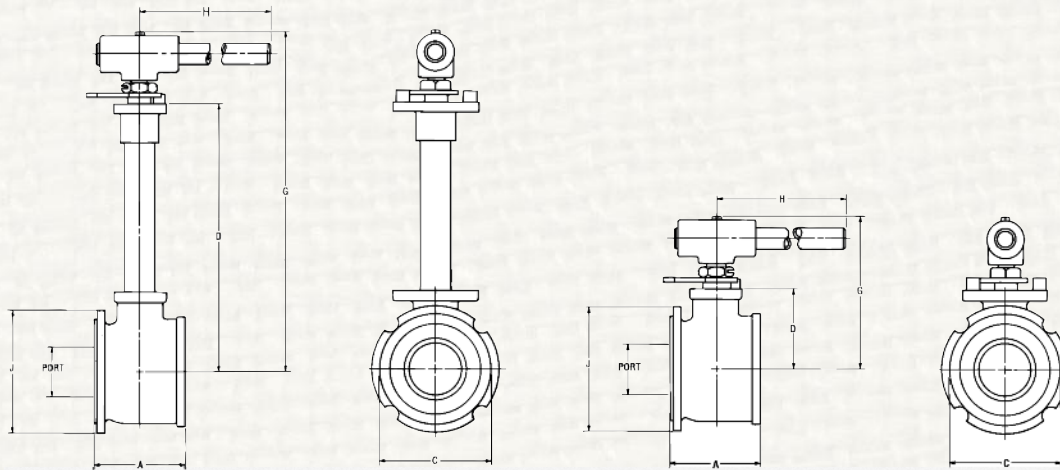

3" - 6" Cryogenic C4 Wafer Ball Valves Extended and Non-extended Bonnets

Valve Size	A	C Diam.	D		G		H	J Diam.	Port Dia.	Approx. Weight - lbs. (kg.)	
			With Ext.	Without Ext.	With Ext.	Without Ext.				With Ext.	Without Ext.
3"	4.50 (114.3)	5.31 (135)	15.38 (391)	3.88 (98.6)	18.73 (476)	7.22 (183.4)	22.0 (559)	5.88 (149)	2.50 (63.5)	27 (12.3)	21 (9.5)
4"	5.81 (147.6)	6.81 (173)	15.94 (405)	4.48 (114)	19.30 (490)	7.84 (199.1)	22.0 (559)	7.50 (190)	3.25 (82.5)	41 (18.6)	34 (15.4)
6"	7.38 (187.5)	8.69 (221)	17.98 (457)	6.19 (157)	23.00 (584)	11.21 (284.7)	26.0 (660)	9.88 (251)	4.38 (111.2)	94 (42.7)	64 (29)

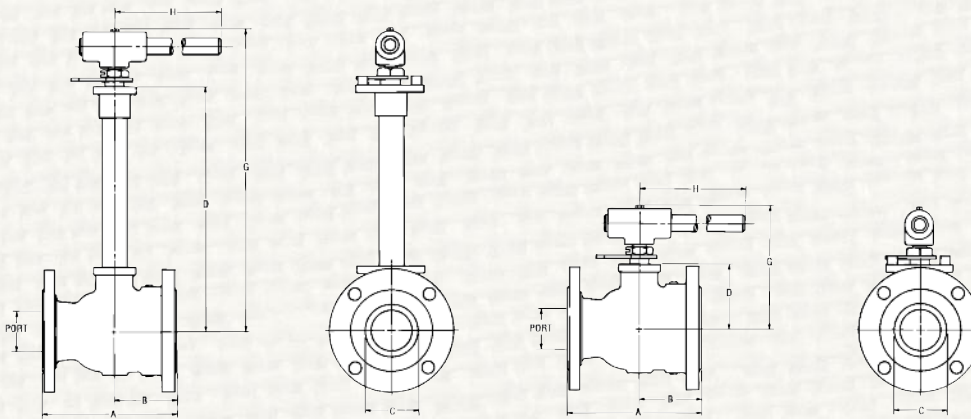

3" - 6" Cryogenic C51 Flanged Ball Valves Extended and Non-extended Bonnets

Valve Size	A	B	C Diam.	D		G		H	Port Dia.	Approx. Weight - lbs. (kg.)	
				With Ext.	Without Ext.	With Ext.	Without Ext.			With Ext.	Without Ext.
3"	8.00 (203.2)	3.62 (91.9)	3.06 (77.7)	15.38 (391)	3.88 (98.6)	18.73 (476.0)	7.22 (183.4)	22.0 (549)	2.50 (63.5)	46 (20.9)	39.5 (17.9)
4"	9.00 (228.6)	4.00 (101.6)	4.03 (102)	15.94 (405)	4.48 (114.0)	19.30 (490.0)	7.84 (199.1)	22.0 (559)	3.25 (82.5)	69 (31.3)	62 (28.1)
6"	10.50 (266.7)	4.25 (108.0)	6.06 (154)	17.98 (457)	6.19 (157.0)	23.00 (584.0)	11.21 (284.7)	26.0 (660)	4.38 (111.2)	139 (63.1)	125 (56.7)

Flow Control

How to Order

WC-CN44 - **66** **66** - **P** **M** **SE** - **34** - **V58**

SERIES	BODY: PIPE ENDS	BALL: STEM	SEAT	BODY SEAL	CONNECTION	SIZE	VARIATIONS
WC-C44 with Stem Extension WC-CN44 without Stem Extension	1- Brass 6- 316 Stainless Steel	1- Brass 6- 316 Stainless Steel	P- Polyfill	M- TFE Coated Stainless Steel	SE- Screw End any Sch. pipe Brass or 316 S.S.† SW- Socket Weld any Sch. Pipe Brass or 316L S.S.† SWO- Socket Weld OD Tube 316L S.S.** BW1- Butt Weld Sch. TE- Solder/Sweat Ends. Brass only Type K, L, or M Copper Tube	14- 1/4" 38- 3/8" 12- 1/2" 34- 3/4" 1- 1" 112- 1 1/2" 2- 2"	V5- Hydrostatic Testing V6- Source Inspection V14- Handleless Valves 3" - 6" V32- Stainless Steel Oval Handle 1/4" - 2"
<i>Diverter (Porting option 1)</i> WC-C44V1 with Stem Extension WC-CN44V1 without Stem Extension <i>Diverter (Porting option 2)</i> WC-C44V2 with Stem Extension WC-CN44V2 without Stem Extension	1- Brass 6- 316 Stainless Steel	1- Brass 6- 316 Stainless Steel	P- Polyfill	M- TFE Coated Stainless Steel	SE- Screw End any Sch. pipe Brass or 316 S.S.† SW- Socket Weld any Sch. Pipe Brass or 316L S.S.† SWO- Socket Weld OD Tube 316L S.S.** TE- Solder/Sweat Ends. Brass only Type K, L, or M Copper Tube	12- 1/2" 34- 3/4" 1- 1" 112- 1 1/2" 2- 2"	V36- Certificate of Compliance V48- Extended Lever Handle V58- B16.34 Compliance
<i>Wafer</i> WC-C4 with Stem Extension WC-CN4 without Stem Extension	1- Brass 6- 316 Stainless Steel	1- Brass 6- 316 Stainless Steel	P- Polyfill	T- TFE	151- between ANSI 150# flanges 301- between ANSI 300# flanges	3- 3" 4- 4" 6- 6"	V59- Extended Oval Handle 1/4" - 2" V60- Locking Mechanism on Std. Lever Handle
<i>Flanged</i> WC-C51 with Stem Extension WC-CN51 without Stem Extension	1- Brass 6- 316 Stainless Steel	1- Brass 6- 316 Stainless Steel	P- Polyfill	T- TFE	151- ANSI 150 (ANSI 300 available as a custom product)	3- 3" 4- 4" 6- 6"	

* Non-extended stem valves are designed for intermittent cryogenic service (drains, vents, sampling and small Dewar drain and fill).

**SWO not available in 1/4", 3/8".

††All stems are stainless steel with brass or stainless steel balls.

†All IPS schedules of stainless steel pipe, S.P.S. copper pipe and red brass pipe.

NOTE: For low temperature ammonia applications, welded extended bonnet must be used.

Place the designation V-58 for B16.34 compliance at the end of the valve ordering code. See page 37M-5.

Ordering example above is a 3/4" three-piece cryogenic ball valve with stainless steel body, pipe ends, ball and stem, Polyfill seats, TFE coated stainless steel body seal, screw ends with no extension, B16.34 Compliant.

CAUTION: Ball valves can retain pressurized media in the body cavity when closed. Use care when disassembling. Always open valve to relieve pressure prior to disassembly. Due to continuous development of our product range, we reserve the right to alter the product specifications contained in this leaflet as required.
CRYOGENS CAN CAUSE SEVERE BURNS, SUFFOCATION OR OTHER SERIOUS INJURIES. ENVIRONMENTS CONTAINING CRYOGENIC VALVES NEED PROPER VENTILATION AND LOW OXYGEN WARNING DEVICES.

Polyfill® is a registered trademark of Flowserve Corporation.

Pulsair® is a registered trademark of Flowserve Corporation.

Praxair® is a registered trademark of Praxair Technology, Inc.

Molykote® is a registered trademark of The Alpha Molykote Corporation.

DataFlo™ is a trademark of Worcester Controls.

Whatman® is a registered trademark of Whatman Limited.