

Fill Cluster

Type 07017 - Fill cluster with check function



Cryogenic-Fill cluster, PN50

Stainless steel body and topwork
with check function and drain valve
"live loaded" gland packing
"cleaned and degreased for oxygen service"

Part No. 07017.X.5000

Fill connection: Air Liquide specified flange
Socket weld connection for stainless steel pipes
acc. to ISO 1127 or ASTM A312
Non-return unit metal to metal seated, leakage rate D acc. to EN12266-1

Available options - on request only:

- other fill connections
- integrable strainer



Applications:

Applications: Approved for air gases, vapours and cryogenic liquefied gases incl. LNG.
Working temperature: -196°C / -321°F (77K) up to +120°C / +248°F (393K)

Materials	DIN EN	ASTM
1 Fill body	1.4308	A 351 CF8
2 Body	1.4308	A 351 CF8
3 Valve seal	PTFE / Carbon filled (25%)	
4 Disc	1.4301	A 276 Grade 304
5 Bonnet gasket	PTFE	
6 Headpiece	1.4308	A 351 CF8
7 Bolts	1.4301/A2	A 194 B8
8 Elongation tube	1.4541	A 213 TP 321
9 Stem	1.4301	A 276 Grade 304
10 Gland packing	Graphite / PTFE	
11 Gland nut	1.4305	A 276 Grade 303
12 Handwheel	Aluminium alloy	
13 Bush	CW452K	B 159 UNS C51900
14 Check disc	1.4301	A 276 Grade 304
15 Spring	1.4571	A 313 Grade 316Ti
16 Cap	1.4301	A 276 Grade 304

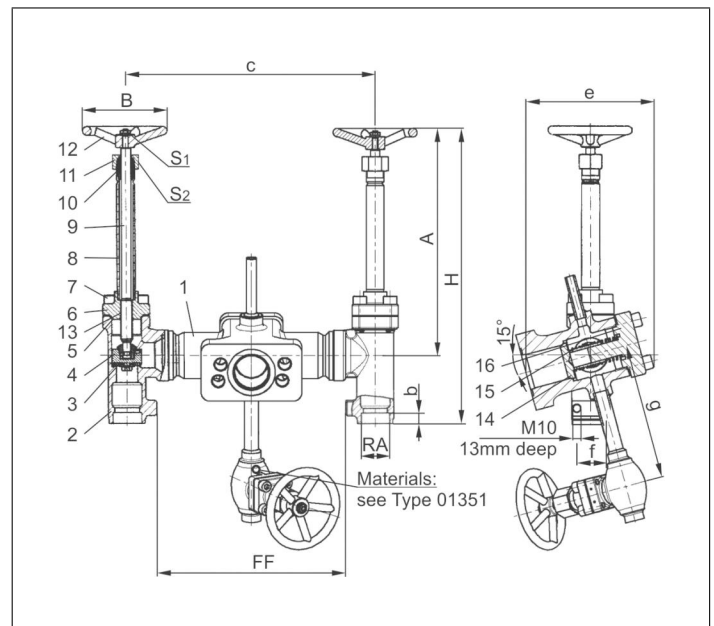

Standard marking acc. to Pressure Equipment Directive 2014/68/EU (PED).



Type 07017 - Standard design	Technical data		
Nominal size	DN	25	40
Dimension code	.X.	2533	4048
Face-to-face dimension	FF	225	225
Outside pipe-Ø ISO 1127	RA	33.7	48.3
Outside pipe-Ø ASTM A312	RA	33.40	48.26
Socket depth	b	13	13
Height	A	270	270
Height	H	350	350
Length	c	295	301
Length	e	76	76
Length	f	32	32
Length	g	160	160
Handwheel-Ø	B	100	125
Wrench size across flats	S ₁	7	10
Wrench size across flats	S ₂	30	36
Weight	ca. kg	11.2	14.0

Dimensions in mm.