

Fire Safe Valves

Type 01643 - Actuated Globe Valve



Cryogenic-Globe Valves with Pneumatic Actuator, PN50 (DN150=PN40)
“Fire safe” type test approval acc. to EN ISO 10497

Stainless steel body and topwork
 Actuator - air opens, spring closes
 “live loaded” gland packing
 “cleaned and degreased for oxygen service” - the actuator is not cleaned and degreased for oxygen

Part No. 01643.X.*01*

* Butt weld connection for stainless steel pipes acc. to ISO 1127 or ASTM A312

Part No. 01643.X.*014

Socket weld connection for stainless steel pipes acc. to ISO 1127 or ASTM A312

Available accessories:

- Solenoid valve · Limit switch
- Electropneumatic positioner etc.

Available options - on request only:

- Welded stainless steel stubs acc. to ISO 1127 or ASTM A312 - length FF + 200mm
- Actuator “cleaned and degreased for oxygen service”



Applications:

Approved for air gases, vapours and cryogenic liquefied gases incl. LNG.

Working temperature: -196°C / -321°F (77K) up to +120°C / +248°F (393K)

Materials	DIN EN	ASTM
1 Body	1.4308	A 351 CF8
2 Valve seal	PTFE / Carbon filled (25%)	
3 Disc	1.4301	A 276 Grade 304
4 Bonnet gasket	Graphite	
5 Headpiece	1.4301	A 276 Grade 304
6 Bolts	1.4301/A2	A 194 B8
7 Elongation tube	1.4541	A 213 TP 321
8 Stem	1.4301	A 276 Grade 304
9 Gland packing	Graphite / PTFE / MICA	
10 Gland nut	1.4305	A 276 Grade 303
11 Pillars	1.4404	A 276 Grade 316L
12 Bush	CW452K	B 159 UNS C51900

Standard marking acc. to Pressure Equipment Directive 2014/68/EU (PED).

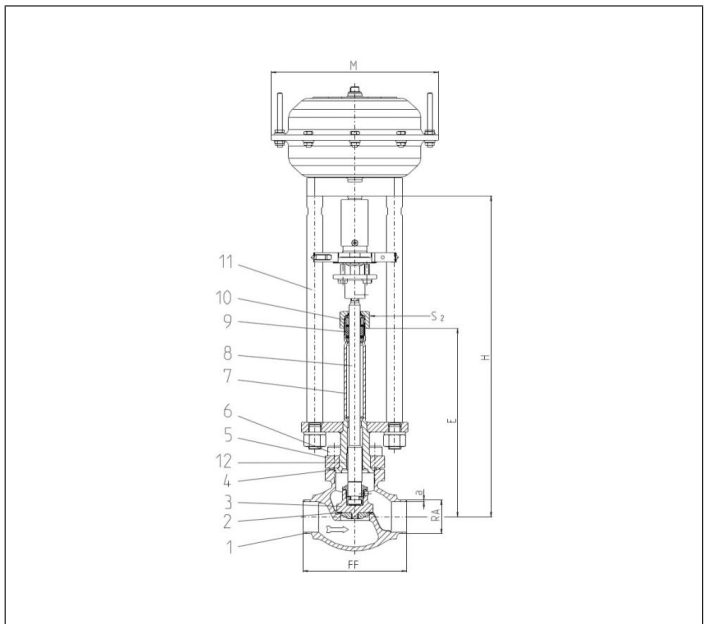

Type 01643 - Standard design	Technical data														
	Nominal size	DN	10	15	15	20	25	32	40	40	50	65	80	100	150
Dimension code	.X.	1012	1517	1521	2026	2533	3238	4042	4048	5060	657x	8088	0114	0168	
Face-to-face dimension	FF	70	85	85	100	115	115	130	130	155	205	245	280	400	
Height	H	370	370	370	370	375	405	420	420	425	510	575	635	685	
Length	E	195	195	195	200	200	230	230	230	235	300	300	300	300	
Outside pipe-Ø ISO 1127	RA	12.0	17.2	21.3	26.9	33.7	38.0	42.4	48.3	60.3	76.1	88.9	114.3	168.3	
Wall thickness pipe ISO 1127	a	1.0	1.6	2.0	2.0	2.0	2.0	2.0	2.0	2.0	2.6	3.2	6.0	7.1	
Outside pipe-Ø ASTM A312	RA	13.72	17.15	21.34	26.67	33.40	-	42.16	48.26	60.33	73.03	88.90	114.3	168.3	
Wall thickness pipe ASTM A312	a	dimensions acc. to S10 or S40													
Socket depth	b	6	10	10	13	13	-	13	13	16	16	16	20	20	
Actuator-Ø	M	dependent on actuator													
Wrench size across flats	S ₂	30	30	30	30	30	36	36	36	36	36	36	41	41	
Weight w/o actuator	ca. kg	1.9	2.15	2.2	2.4	3.1	3.8	6.5	6.5	9.0	15.2	20.0	28.0	60.9	
Kvs-Value	m ³ /h	1.6	3.8	4.3	6.7	11.5	14.0	20.6	22.6	37.1	71.1	104.0	170.0	350.0	
Cv-Value	gal/min	1.9	4.4	5.0	7.8	13.4	16.2	23.9	26.3	43.2	82.7	120.9	195.2	401.8	
Stroke	mm	10	10	10	7	9	9	11	11	15	23	23	30	40	

Dimensions in mm. Compliance of tightness requirements acc. to EN 1626 for DN150 up to 20 bar differential pressure. In the range of >20-40 bar, 350-700ml (1 bar, 20°C [68°F]) are reached.