

GEM
GEM
GEM
SERIES

DESCRIPTION:

GEM Series combo pressure build – economizer regulators offer optimum performance for cryogenic liquid cylinders. The regulators are designed for fast pressure building, steady head pressure during all use conditions, and maximum efficiency economization when cylinder pressure is near relief valve setting. The pressure-build and economizer functions are completely separated which eliminates function overlap and improves overall cylinder efficiency. GEM Series regulators provide high flow and quick, positive shut off at the desired set pressure. Solid, non-tied diaphragm allows for leak-free and long-lasting performance. All GEM Series regulators are supplied factory pre-set and cleaned for oxygen service.

FEATURES:

- **OPTIMIZED FOR CRYOGENIC LIQUID CYLINDERS:** Designed to exceed the PB and Economizer performance of current market offerings for cryogenic liquid cylinders.
- **SEPARATE PB AND ECON FUNCTIONS:** Design maintains separation between pressure build and economizer functions to eliminate overlap.
- **MAXIMIZED ECONOMIZER FLOW:** Regulators are designed for maximum economizer flow performance, minimizing product loss.
- **SOLID, NON-TIED, DIAPHRAGM:** Solid diaphragm eliminates potential leak path and increases sensitivity.
- **CLEANED FOR OXYGEN SERVICE:** Regulators are cleaned for use in Oxygen service standard.

TECHNICAL DATA:

Max Inlet Pressure: 600 PSI (41.4 bar)

Spring Ranges and Adjustment Coefficients:

Spring	Outlet Pressure Range	PSI/Turn*
B	50 to 200 PSI (3.4 to 13.8 bar)	28
C	150 to 350 PSI (10.3 to 24.1 bar)	36
D	300 to 500 PSI (20.7 to 34.5 bar)	56

* PSI / Turn Value is approximate change in setpoint per full turn of the adjustment screw (CW to increase, CCW to decrease), for reference only.

Temperature Range: -320° to 150 °F (-196° to 65 °C)

MATERIALS OF CONSTRUCTION:

Component	Material
Body, Chamber, Chamber Ring, Valve Body, Stem, Spring Button, Spring Retainer, Bottom Plug, Inner Bonnet	CDA 360 Brass, ASTM B16
Adjustment Springs	17-7 PH SS, ASTM A313
Adjustment Screw and Locknut	18-8 Stainless Steel
Valve Spring	302 SS, ASTM A313
Diaphragms	Phosphor Bronze
Valve Seal and Stem Diaphragms	PTFE
Chamber and Bottom Plug Seal	Gylon®

NOTE: Regulators are assembled with Dupont Krytox® lubricant.

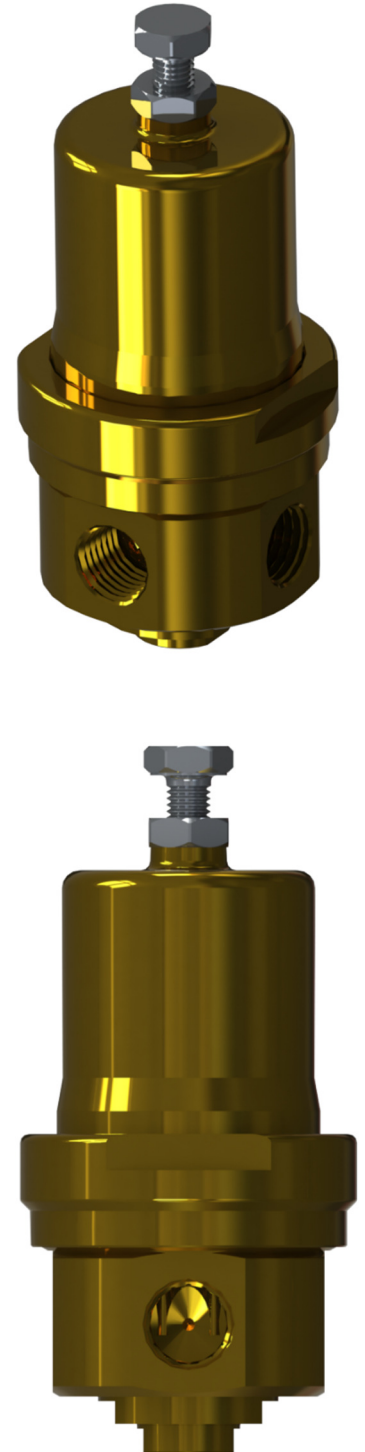

COMBO PRESSURE BUILD – ECONOMIZER

DIMENSIONAL DATA

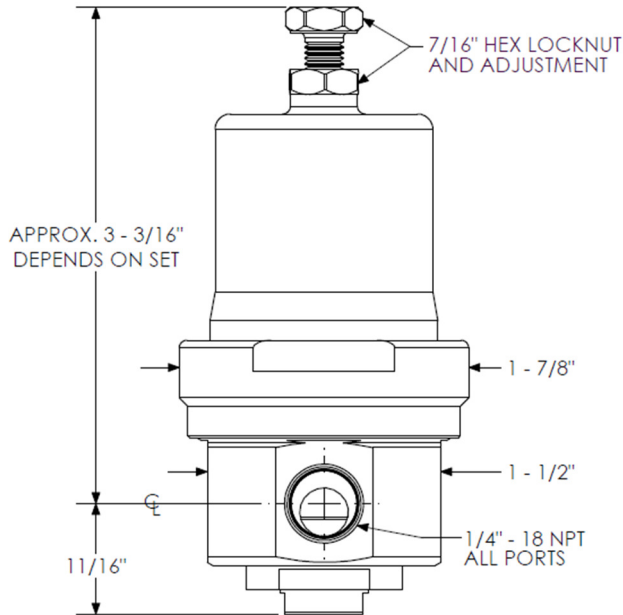

PORT CONFIGURATIONS

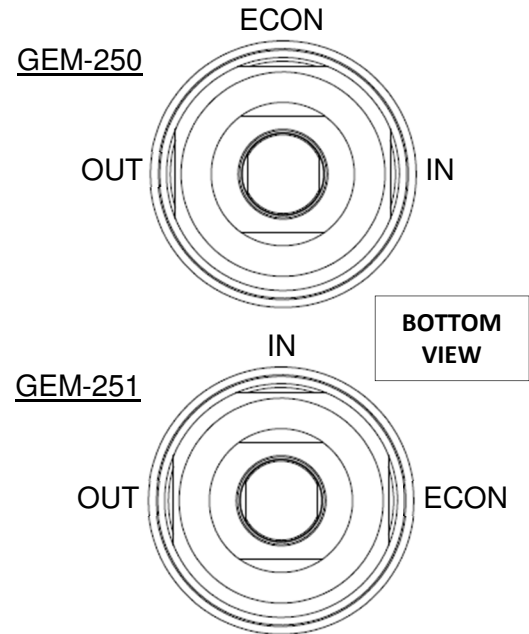

PERFORMANCE AND SETTING INFORMATION

BENCH SETTING AND TESTING

Regulators are 100% Factory Preset to desired Set Pressure (See How to Order below).

IMPORTANT: When setting off the cylinder (bench setting), it is important that the outlet and economizer ports are connected to avoid damage to the regulator.

Consult factory for specific instructions for proper bench setting and testing (Document EN-FR-160).

QUALIFIED PERFORMANCE

High Flow Design results in Reduced Pressure Build Time and Higher Steady State Pressure during high use periods.

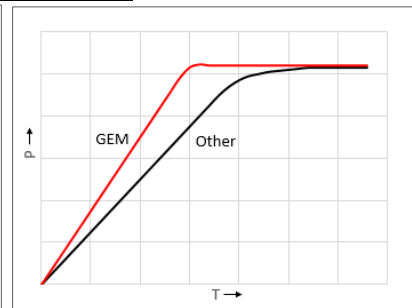

Extensively field qualified. OEM Approved & Endorsed.

HOW TO ORDER / REPAIR KITS

GEM - 250 - C - 300

SERIES / PORT CONFIGURATION

GEM-250 - GEM Regulator, Side Econ

GEM-251 - GEM Regulator, Side Inlet

* see Port Config. reference above

SET PRESSURE

Specify set pressure in PSI
OMIT FOR STANDARD SET (BY SPRING, SEE TABLE)

SPRING RANGE

B - 50 to 200 PSI (3.4 to 13.8 bar)

C - 150 to 350 PSI (10.3 to 24.1 bar)

D - 300 to 500 PSI (20.7 to 34.5 bar)

Spring	Std. Set
B	125 PSI
C	300 PSI
D	450 PSI

Standard Sets do not come engraved with "Factory Set Pressure."

P/N	Description
GEM-RK	Full Repair Kit: contains all seals, diaphragms, valve, stem, stem spring and valve spring.
GEM-V-RK	Valve Only Repair Kit: contains bottom plug seal, valve and valve spring.

PROPER COMPONENT SELECTION – When specifying a component, the total system design must be considered to ensure safe and trouble-free performance. Intended component function, materials compatibility, pressure ratings, installation, environment and maintenance are the responsibility of the system designer.

GENERANT

Valves & **BI-Lok** Fittings

www.generant.com

1865 Route 23 South PO Box 768 Butler, New Jersey 07405 973.838.6500 Fax 973.838.4888